

FOR USE IN 5730,5820,5830 MACHINES

REVISIONS		REV	
REV	DESCRIPTION	BY	DATE

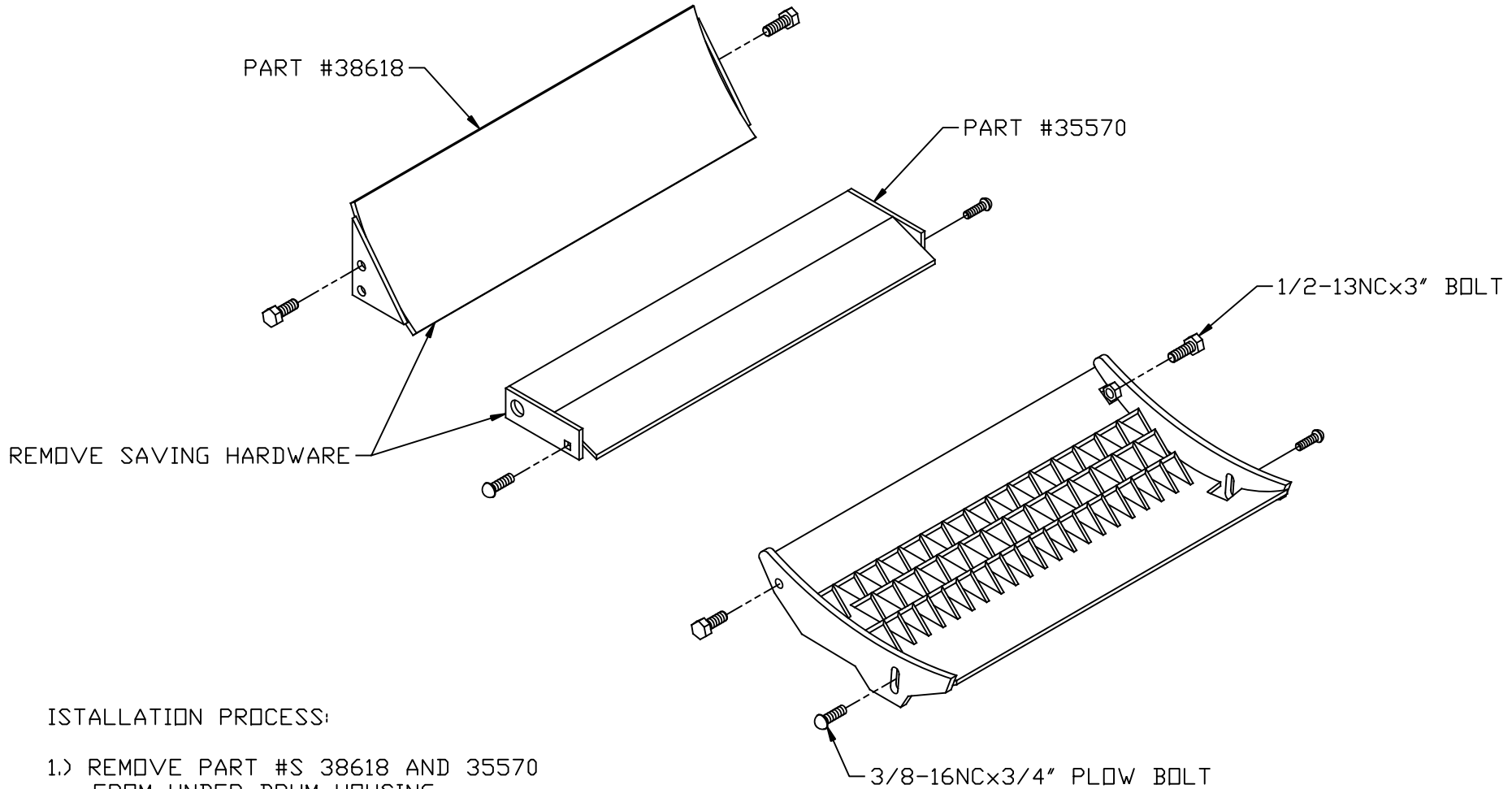

INSTALLATION PROCESS:

- 1.) REMOVE PART #S 38618 AND 35570 FROM UNDER DRUM HOUSING.
- 2.) USING EXISTING HOLES FROM PARTS REMOVED INSTALL CRACKER PLATE USING SAME HARDWARE.
- 3.) ADJUST CRACKER PLATE USING PLOW BOLT AND SLOTTED HOLE IN REAR (ADJUSTMENT SHOULD BE APPROX. 1/16" TO 1/8" AWAY FROM CRACKER KNIVES)

THIS DRAWING IS THE PROPERTY OF KOOIMA CO. AND IS PROVIDED WITH THE UNDERSTANDING THAT IT NOT BE USED IN ANY WAY DETRIMENTAL TO THE INTERESTS OF KOOIMA CO.	
DRAWN BSM	DATE 8-24-99
CHECKED	DATE
SCALE 1:5	BREAK ALL EDGES .03 X 45°
DIMENSIONS ARE IN INCHES TOLERANCES UNLESS SPECIFIED FRACTIONAL ± 1/32 3 PLACE ± .005 2 PLACE ± .020 ANGULAR ± 1°	
MATERIAL AS NOTED	

Kooima Company
Laser

2638 310th Street Phone (712) 476-5600
Rock Valley, Iowa 51247 FAX (712) 476-5403

**JD 5830 CRACKER PLATE
INSTALLATION PRINT**

PART NO. 5830

DWG. NO. MISC\40049